

The information in this document is subject to change without notice and should not be construed as a commitment by ABB. ABB assumes no responsibility for any errors that may appear in this document.

Except as may be expressly stated anywhere in this document, nothing herein shall be construed as any kind of guarantee or warranty by ABB for losses, damages to persons or property, fitness for a specific purpose or the like.

In no event shall ABB be liable for incidental or consequential damages arising from use of this document.

This document and parts thereof must not be reproduced or copied without ABB's written permission, and contents thereof must not be imparted to a third party nor be used for any unauthorized purpose. Contravention will be prosecuted.

Additional copies of this document may be obtained from ABB at its then current charge.

© Copyright 2017 ABB ALL right reserved.

ABB AB

SE-721 68 Västerås  
Sweden

Latest revision: ECO 95019, WI 172257  
Page 2: Page 4A & 4B; 110A & 110B added  
Page 3: 3HAC062246-001 was 3HAC043206-001.  
Page 5/2/5: NC & screen con. to earth added.  
Page 4A was page 4 & page 4B is new.  
Page 110A was page 110 & page 110B is new.



Lab/Office:  
RMRO SE/  
PRIM

IRB 4600

COPYRIGHT page

Status: 2017-12-21

APPROVED

Document no.

3HAC029038-003

Plant: = IRB 4600  
Location: + Manipulator  
Sublocation: +

Rev. Ind Page1

05 2  
Total 19

Prepared by, date: Erik Mesaros Approved by, date: JanErik Nähls

We reserve all rights in this document and in the information contained therein. Reproduction, use or disclosure to third parties without express authority is strictly forbidden. © Copyright 2003 ABB

# Table of contents

ABB Contents1

Page	Page description	Comment
1	COPYRIGHT page	
2	Table of contents: (1 - 110)	
3	Valid For	
4A	Connection point location, old. With multibus harness 3hac029864-001.	
4B	Connection point location, new. With multibus harness 3hac062246-001.	
5	Legend	
10	Brake Release Unit	
20	Serial Measuring Board	Incl. optional cable harness axis 7
30	Axis 1	Incl. optional cooling fan 1
40	Axis 2	Incl. optional cooling fan 2
50	Axis 3	Incl. optional signal lamp
60	Axis 4	
70	Axis 5	
80	Axis 6	
90	Customer connection (CP)	
100	Customer connection (CS)	
110A	Multibus, old. With harness 3HAC029864-001	
110B	Multibus, new. With harness 3HAC062246-001	
120	Profibus	

We reserve all rights in this document and in the information contained therein. Reproduction, use or disclosure to third parties without express authority is strictly forbidden. © Copyright 2003 ABB

**Latest revision:** ECO 95019, WI 172257  
 Page 2: Page 4A & 4B; 110A & 110B added  
 Page 3: 3HAC062246-001 was 3HAC043206-001.  
 Page 5/2/5: NC & screen con. to earth added.  
 Page 4A was page 4 & page 4B is new.  
 Page 110A was page 110 & page 110B is new.

Prepared by, date: Erik Mesaros Approved by, date: JanErik Nähls



Lab/Office: IRB 4600  
 RMRO SE/  
 PRIM

Table of contents: (1 - 110)

Status: 2017-12-21

Plant: = IRB 4600  
 Location: + Manipulator  
 Sublocation: +

**APPROVED**

Document no. 3HAC029038-003 Rev. Ind **05**  
 Page 2  
 3  
 Total 19

We reserve all rights in this document and in the information contained therein. Reproduction, use or disclosure to third parties without express authority is strictly forbidden. © Copyright 2003 ABB

Valid for:

This circuit diagram is valid for the following cable harness assemblies:

- 1) 3HAC029420-001, Cable harness, basic.
- 2) 3HAC4050-1 Signal cable SMB.
- 3) 3HAC030936-001 Cable harness ax.7.
- 4) 3HAC022235-1 Lamp unit.
- 5) 3HAC033857-001 Cooling fan ax.1.
- 6) 3HAC033859-001 Cooling fan ax.2.
- 7) 3HAC029000-001 Cable harness, customer connection.
- 8) 3HAC029864-001 Cable harness, multibus.
- 9) 3HAC037798-001 Cable harness, profibus.

IRB4600 alternative gear & ABB motors

- 10) 3HAC043964-001, Cable harness, basic.
- 11) 3HAC043963-001 Cable harness, customer connection.
- 12) 3HAC062246-001 Cable harness, multibus.
- 13) 3HAC043965-001 Cable harness, profibus.

Latest revision: ECO 95019, WI 172257  
 Page 2: Page 4A & 4B; 110A & 110B added  
 Page 3: 3HAC062246-001 was 3HAC043206-001.  
 Page 5/2/5: NC & screen con. to earth added.  
 Page 4A was page 4 & page 4B is new.  
 Page 110A was page 110 & page 110B is new.



Lab/Office:  
RMRO SE/  
PRIM

IRB 4600

Valid For

Status: 2017-12-21

**APPROVED**

Document no.  
**3HAC029038-003**

Plant: = IRB 4600  
 Location: + Manipulator  
 Sublocation: +

Rev. Ind **05** Page **3**  
 4A  
 Total 19

Prepared by, date: Erik Mesaros Approved by, date: JanErik Nähls

We reserve all rights in this document and in the information contained therein. Reproduction, use or disclosure to third parties without express authority is strictly forbidden. © Copyright 2003 ABB

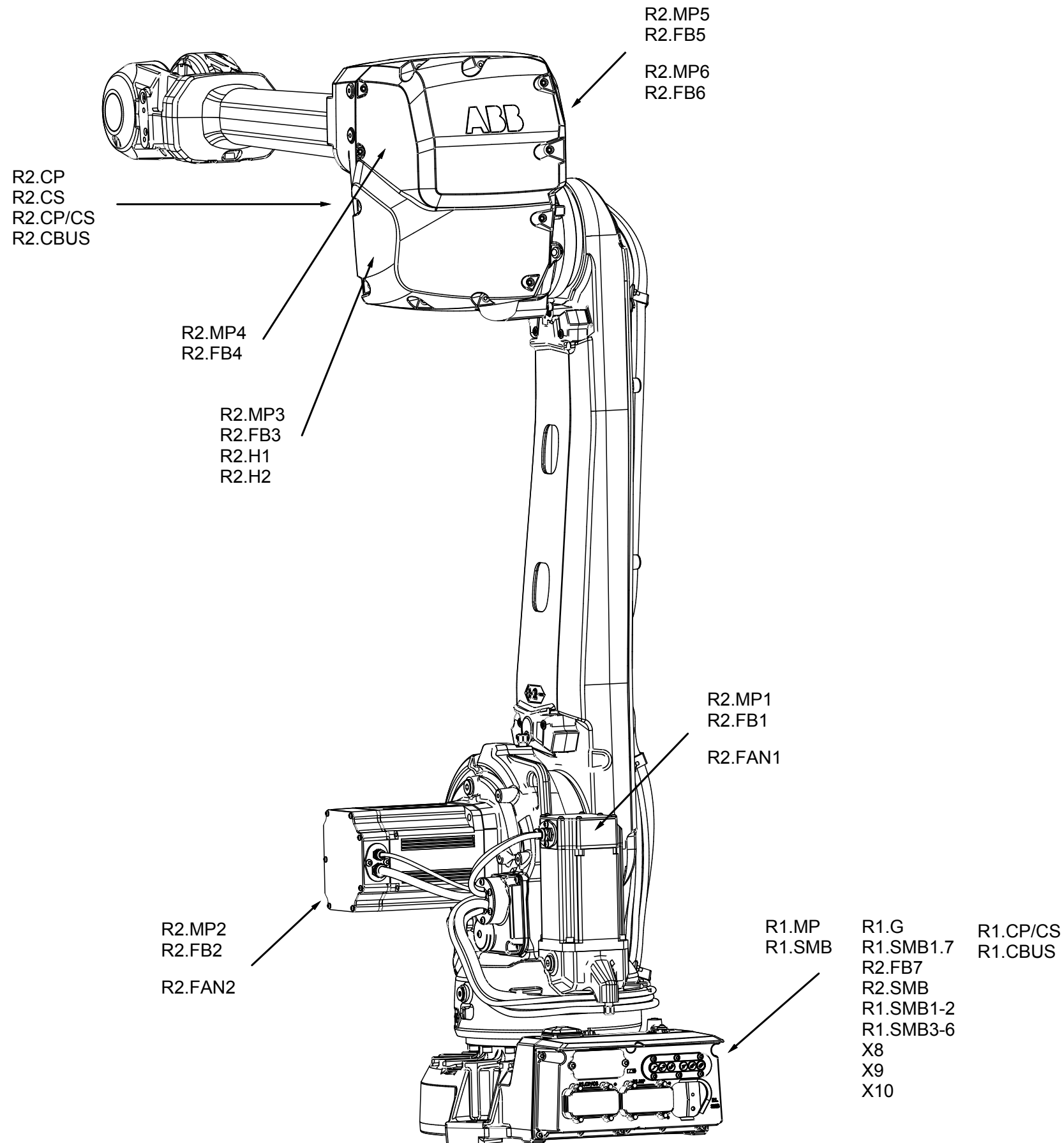

Latest revision: ECO 95019, WI 172257  
 Page 2: Page 4A & 4B; 110A & 110B added  
 Page 3: 3HAC062246-001 was 3HAC043206-001.  
 Page 5/2/5: NC & screen con. to earth added.  
 Page 4A was page 4 & page 4B is new.  
 Page 110A was page 110 & page 110B is new.

Prepared by, date: Erik Mesaros | Approved by, date: JanErik Nähls



Lab/Office:  
 RMRO SE/  
 PRIM

IRB 4600

Connection point location, old

Status: 2017-12-21

**APPROVED**

Document no.

3HAC029038-003

Plant: = IRB 4600  
 Location: + Manipulator  
 Sublocation: +

Rev. Ind Page4A

05 5

Total 19

We reserve all rights in this document and in the information contained therein. Reproduction, use or disclosure to third parties without express authority is strictly forbidden. © Copyright 2003 ABB

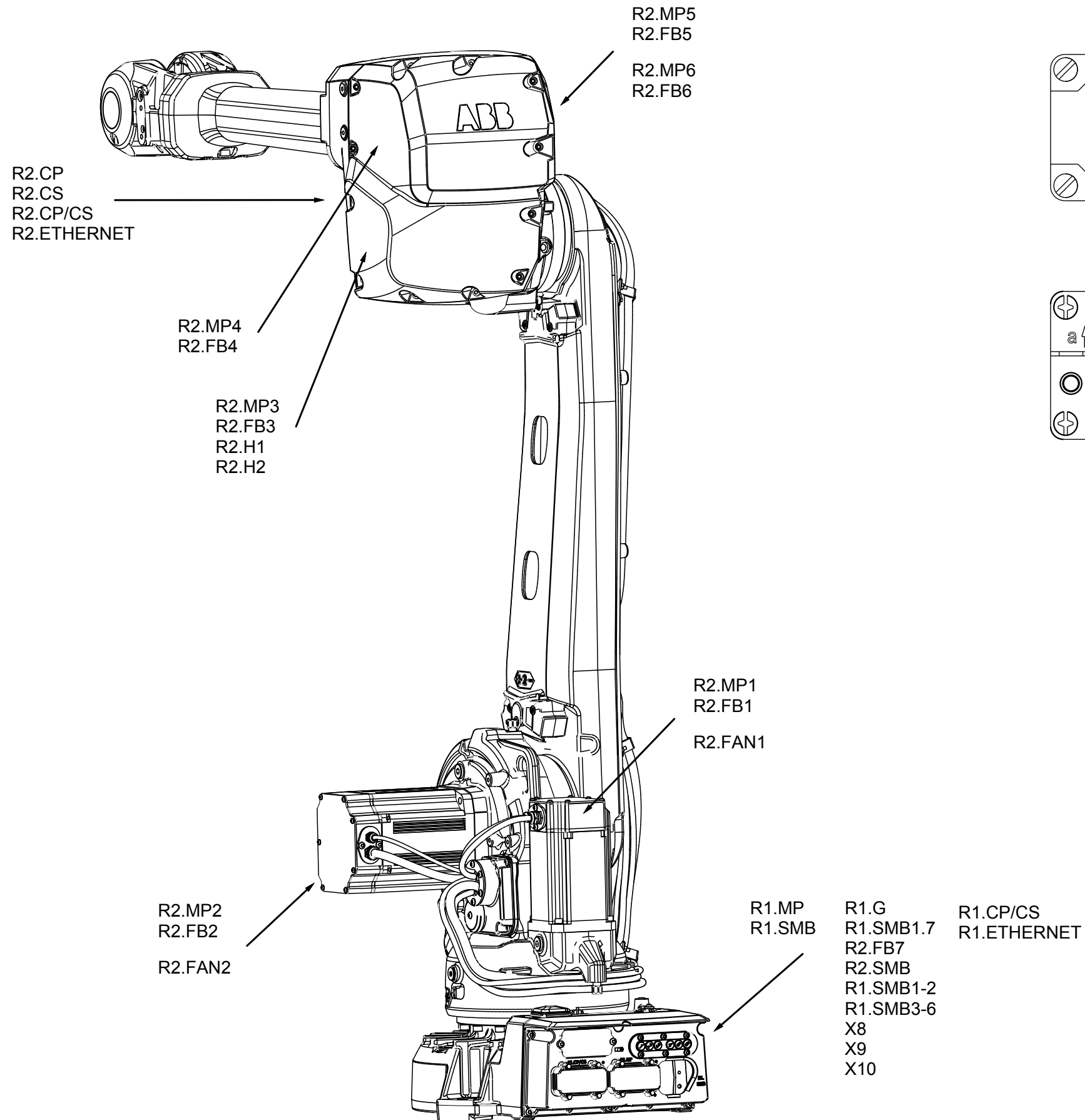

**Latest revision:** ECO 95019, WI 172257  
 Page 2: Page 4A & 4B; 110A & 110B added  
 Page 3: 3HAC062246-001 was 3HAC043206-001.  
 Page 5/2/5: NC & screen con. to earth added.  
 Page 4A was page 4 & page 4B is new.  
 Page 110A was page 110 & page 110B is new.

**Prepared by, date:** Erik Mesaros  
**Approved by, date:** JanErik Nähls



Lab/Office:  
 RMRO SE/  
 PRIM

IRB 4600

Connection point location, new

Status: 2017-12-21

**APPROVED**

Document no.

3HAC029038-003



Plant: = IRB 4600  
 Location: + Manipulator  
 Sublocation: +

Rev. Ind Page4B

**05**

Total 19

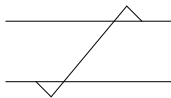
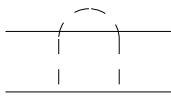
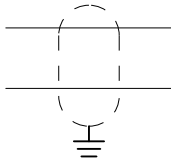
We reserve all rights in this document and in the information contained therein. Reproduction, use or disclosure to third parties without express authority is strictly forbidden. © Copyright 2003 ABB

M	Motor		Protective Earth
R	Resolver		Twisted wires
G	Battery Pack		Screened wires
BU	Brake Release Unit		Screen connected to earth
FB	Feedback unit		
SMB	Serial Measurement Board		
Keypin	Location pin to avoid mismatch		
	NC		Not connected wire

<b>Latest revision:</b> ECO 95019, WI 172257 Page 2: Page 4A & 4B; 110A & 110B added Page 3: 3HAC062246-001 was 3HAC043206-001. Page 5/2/5: NC & screen con. to earth added. Page 4A was page 4 & page 4B is new. Page 110A was page 110 & page 110B is new.		Lab/Office: RMRO SE/ PRIM	IRB 4600	Status: 2017-12-21	Plant: = IRB 4600 Location: + Manipulator Sublocation: +
		Legend	<b>APPROVED</b>	Document no. 3HAC029038-003	Rev. Ind <b>05</b>
Prepared by, date: Erik Mesaros	Approved by, date: JanErik Nähls				

We reserve all rights in this document and in the information contained therein. Reproduction, use or disclosure to third parties without express authority is strictly forbidden. © Copyright 2003 ABB

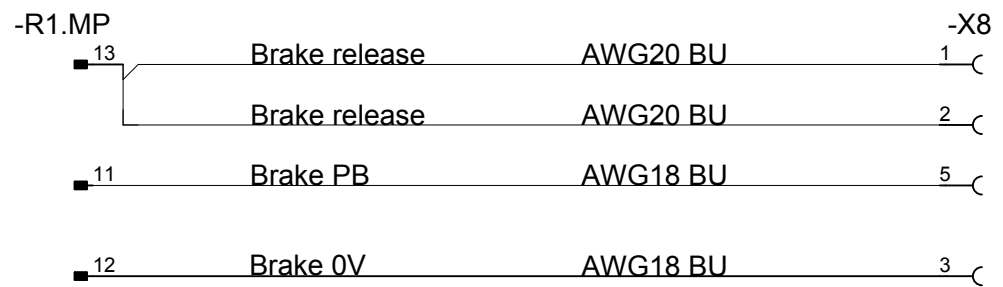

BU Brake Release (Simplified)

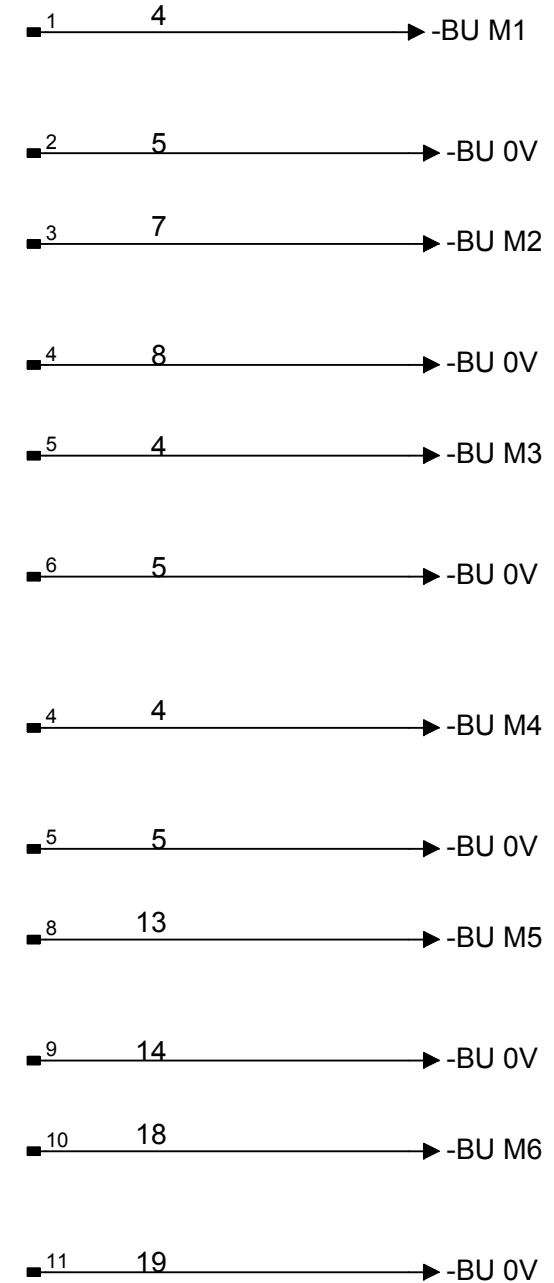
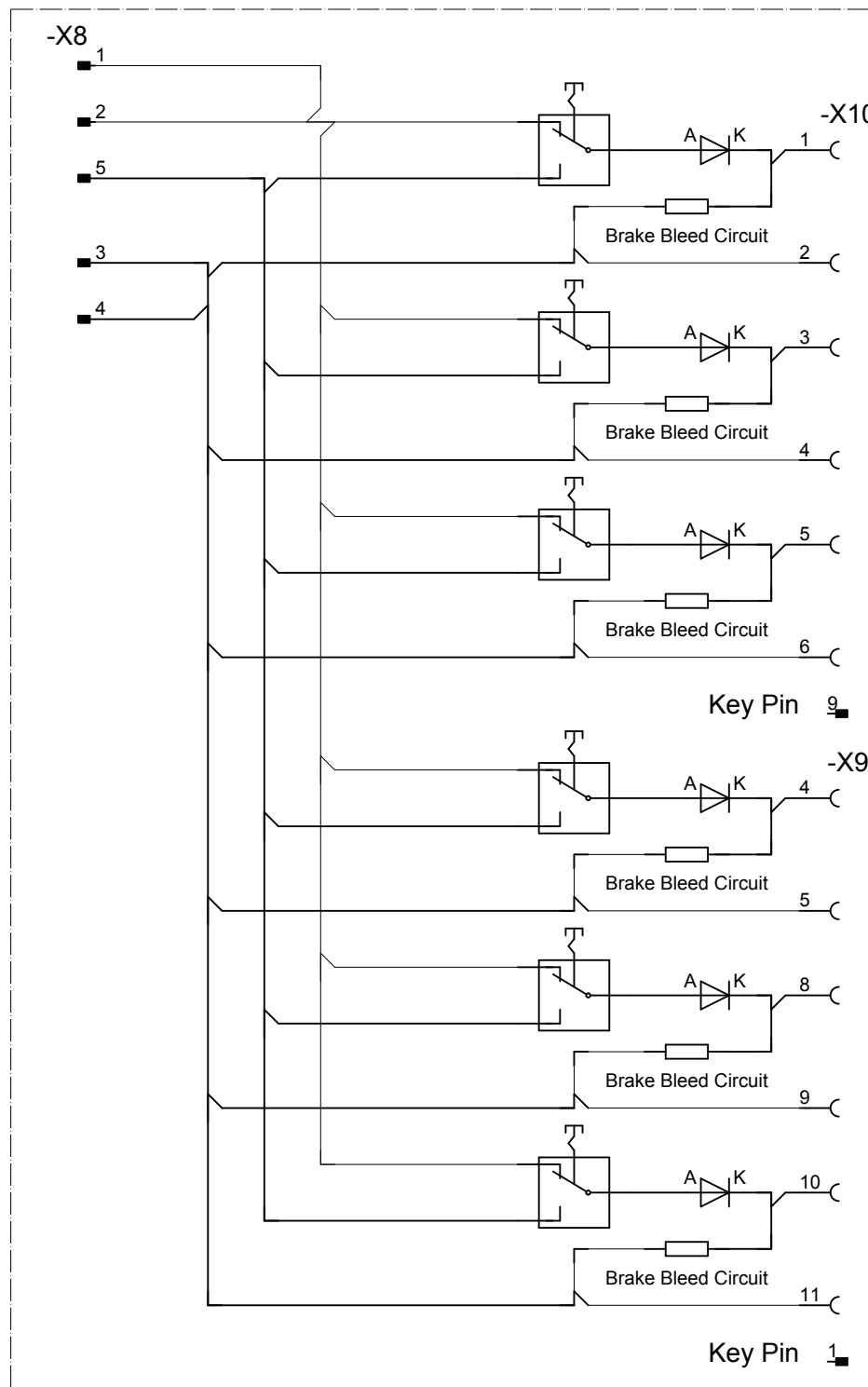

Latest revision: ECO 95019, WI 172257  
 Page 2: Page 4A & 4B; 110A & 110B added  
 Page 3: 3HAC062246-001 was 3HAC043206-001.  
 Page 5/2/5: NC & screen con. to earth added.  
 Page 4A was page 4 & page 4B is new.  
 Page 110A was page 110 & page 110B is new.

Prepared by, date: Erik Mesaros Approved by, date: JanErik Nähls



Lab/Office:  
RMRO SE/  
PRIM

IRB 4600

Brake Release Unit

Status: 2017-12-21

**APPROVED**

Document no.  
3HAC029038-003

Plant: = IRB 4600  
Location: + BU  
Sublocation: +

Rev. Ind Page10  
**05** +SMB/2  
Total 19

We reserve all rights in this document and in the information contained therein. Reproduction, use or disclosure to third parties without express authority is strictly forbidden. © Copyright 2003 ABB

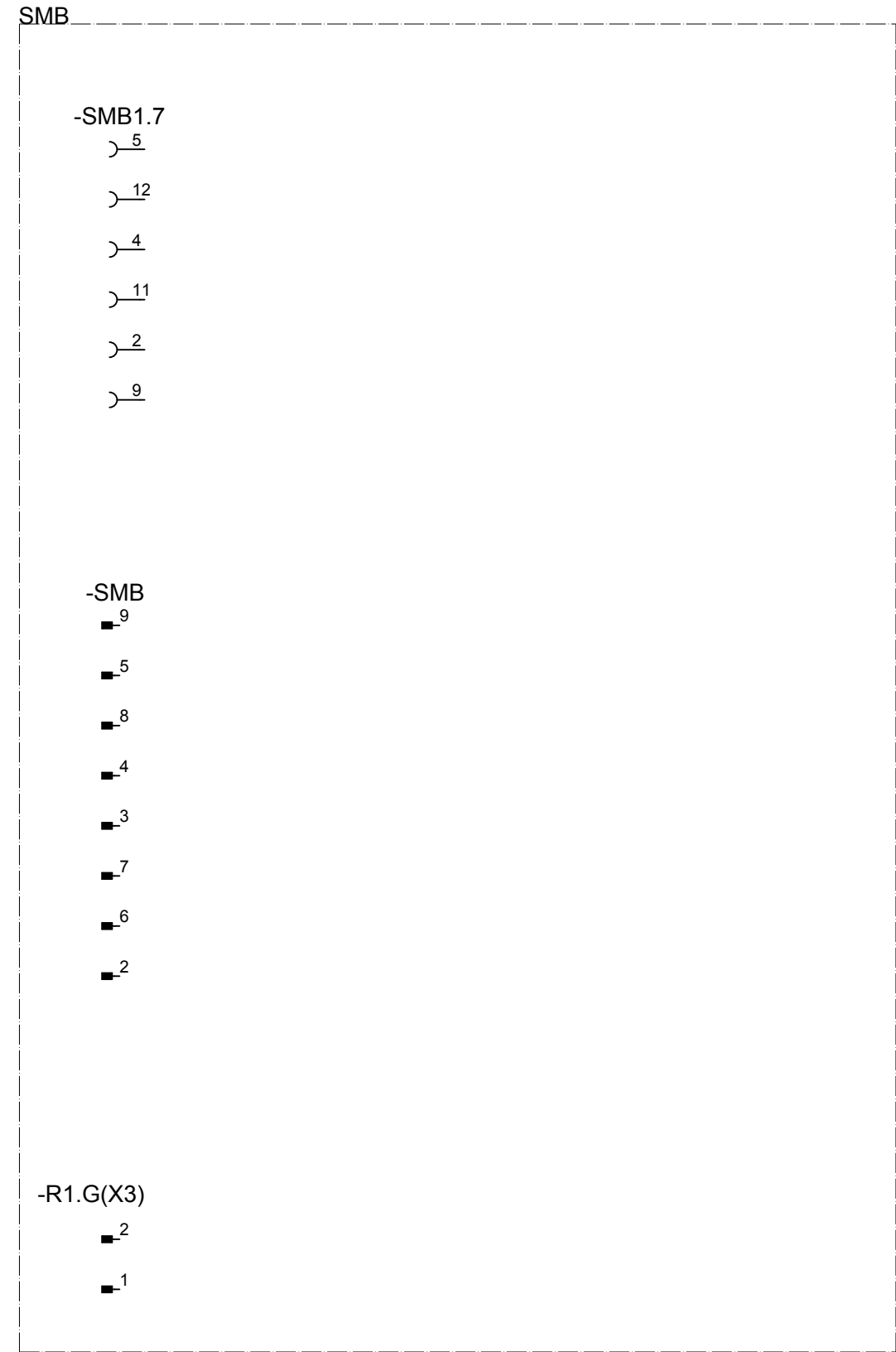
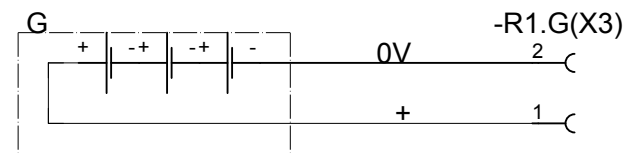
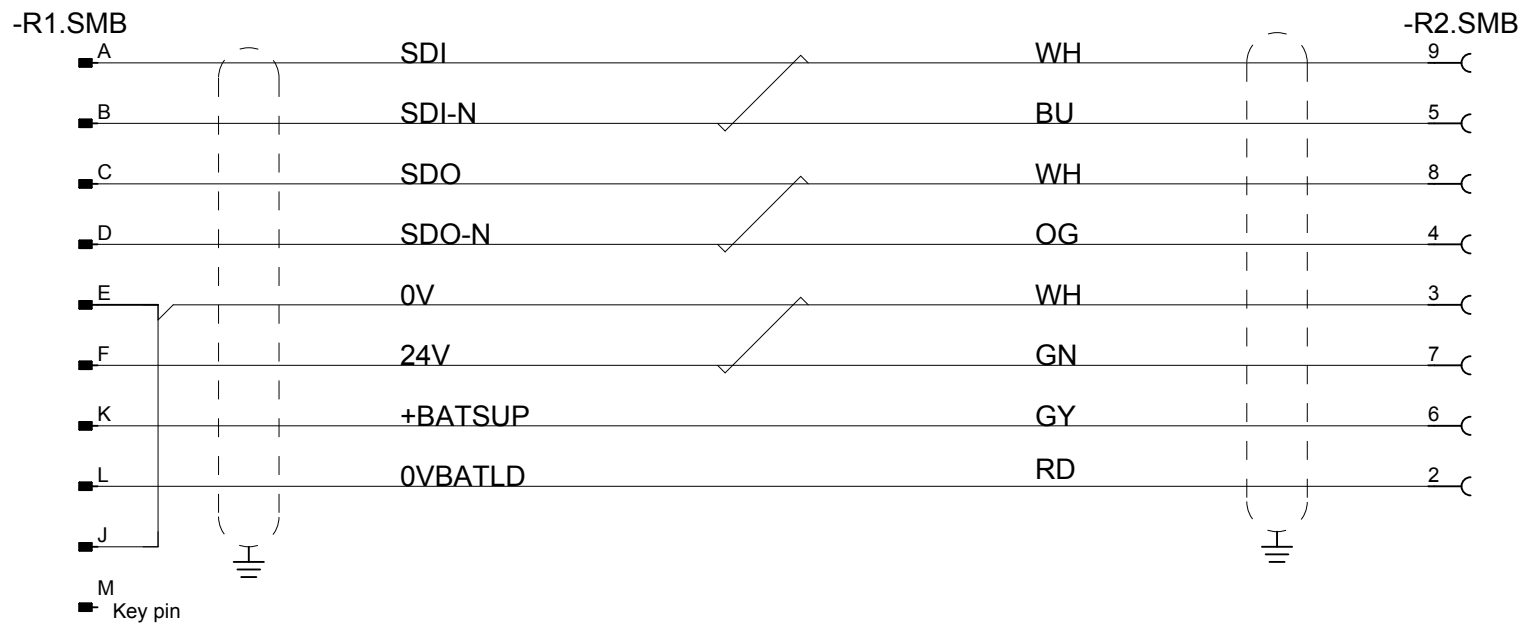
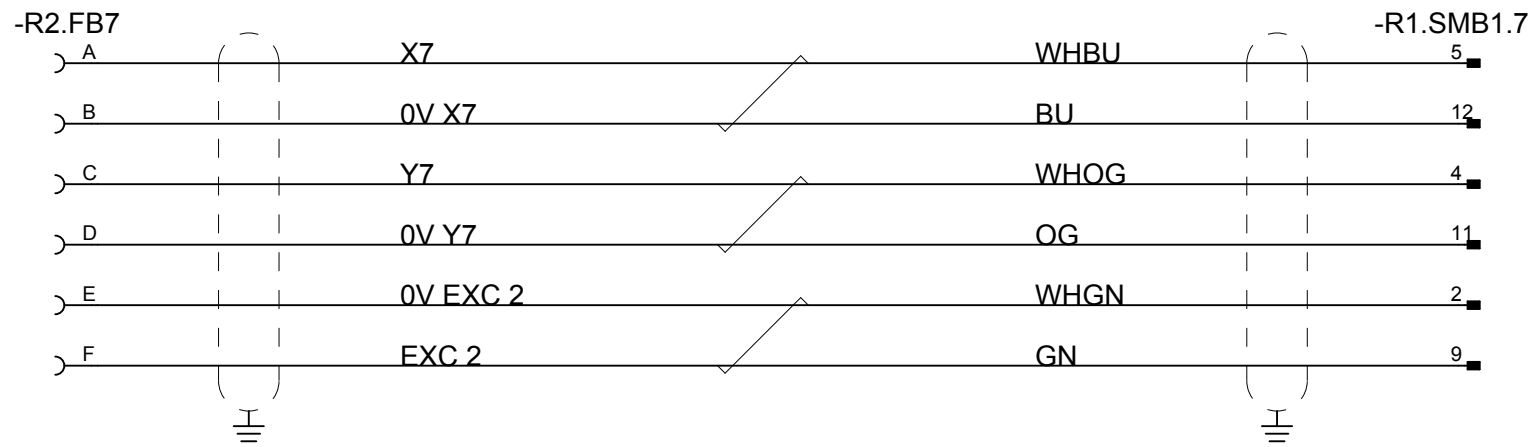

Latest revision: ECO 95019, WI 172257  
 Page 2: Page 4A & 4B; 110A & 110B added  
 Page 3: 3HAC062246-001 was 3HAC043206-001.  
 Page 5/2/5: NC & screen con. to earth added.  
 Page 4A was page 4 & page 4B is new.  
 Page 110A was page 110 & page 110B is new.

Prepared by, date: Erik Mesaros Approved by, date: JanErik Nähls



Lab/Office:  
RMRO SE/  
PRIM

IRB 4600

Serial Measuring Board

Status: 2017-12-21

**APPROVED**

Document no.  
3HAC029038-003

Plant: = IRB 4600  
 Location: + SMB  
 Sublocation: +

Rev. Ind Page20  
**05** +Axis 1  
 Total 19



We reserve all rights in this document and in the information contained therein. Reproduction, use or disclosure to third parties without express authority is strictly forbidden. © Copyright 2003 ABB

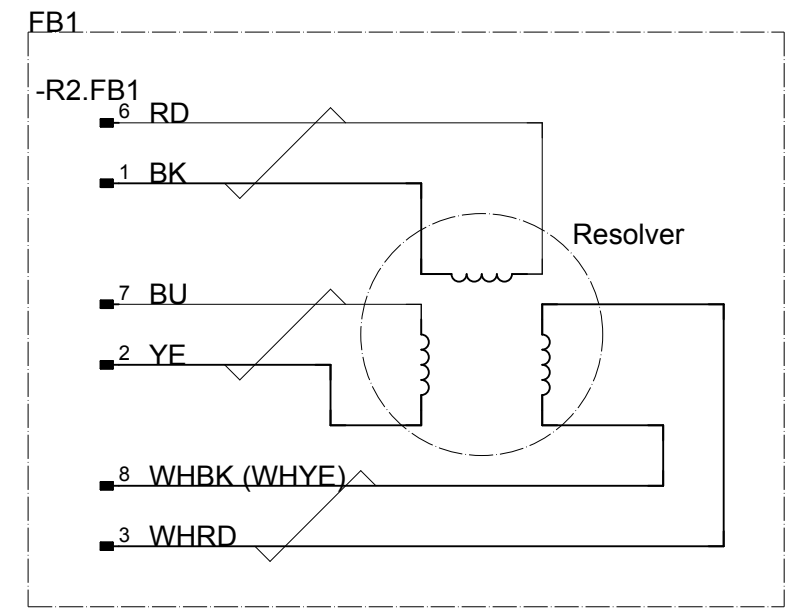
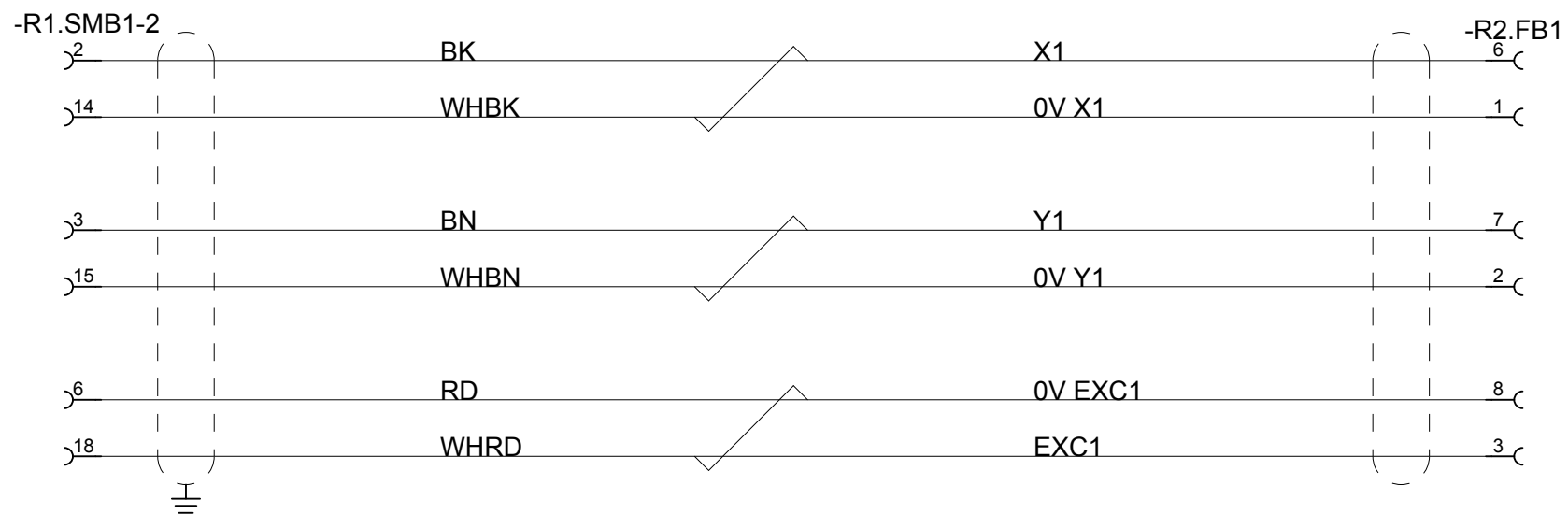
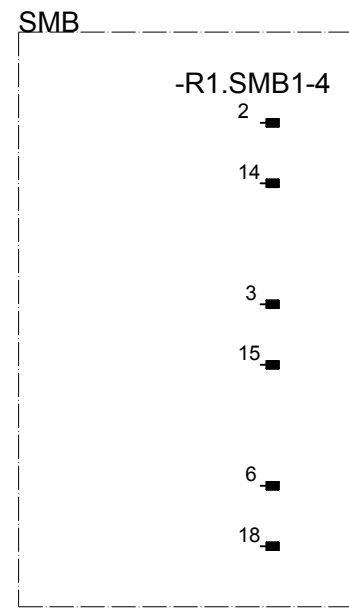
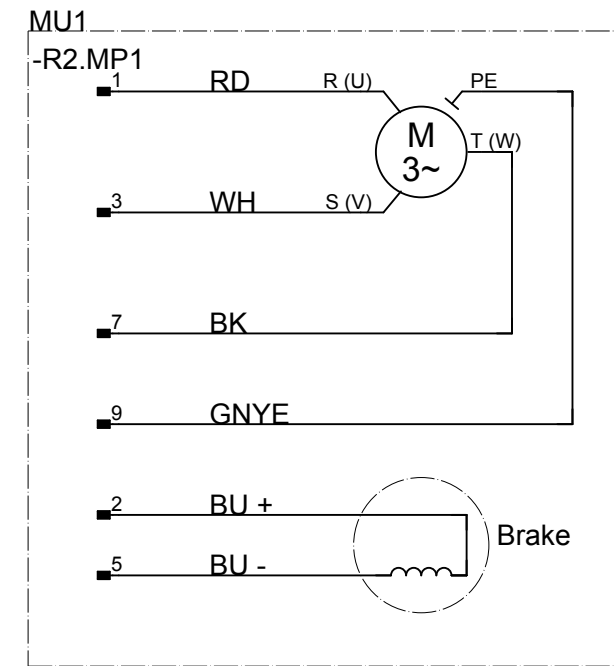
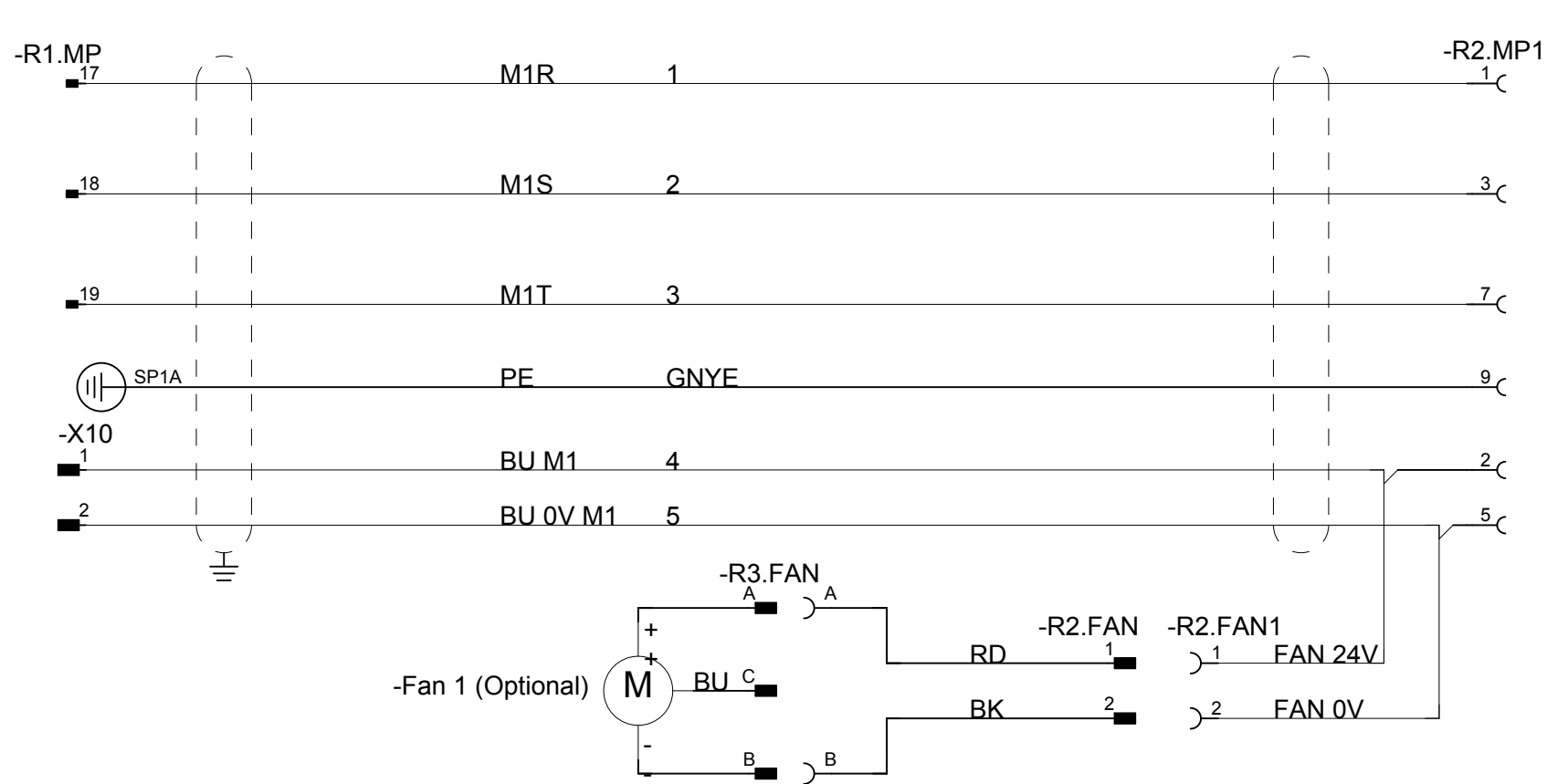

Latest revision: ECO 95019, WI 172257  
 Page 2: Page 4A & 4B; 110A & 110B added  
 Page 3: 3HAC062246-001 was 3HAC043206-001.  
 Page 5/2/5: NC & screen con. to earth added.  
 Page 4A was page 4 & page 4B is new.  
 Page 110A was page 110 & page 110B is new.

Prepared by, date: Erik Mesaros Approved by, date: JanErik Nähls



Lab/Office:  
RMRO SE/  
PRIM

IRB 4600  
Axis 1

Status: 2017-12-21

APPROVED

Document no.  
3HAC029038-003

Plant: = IRB 4600  
Location: + Axis 1  
Sublocation: +

Rev. Ind Page30  
05 +Axis 2  
Total 19

We reserve all rights in this document and in the information contained therein. Reproduction, use or disclosure to third parties without express authority is strictly forbidden. © Copyright 2003 ABB

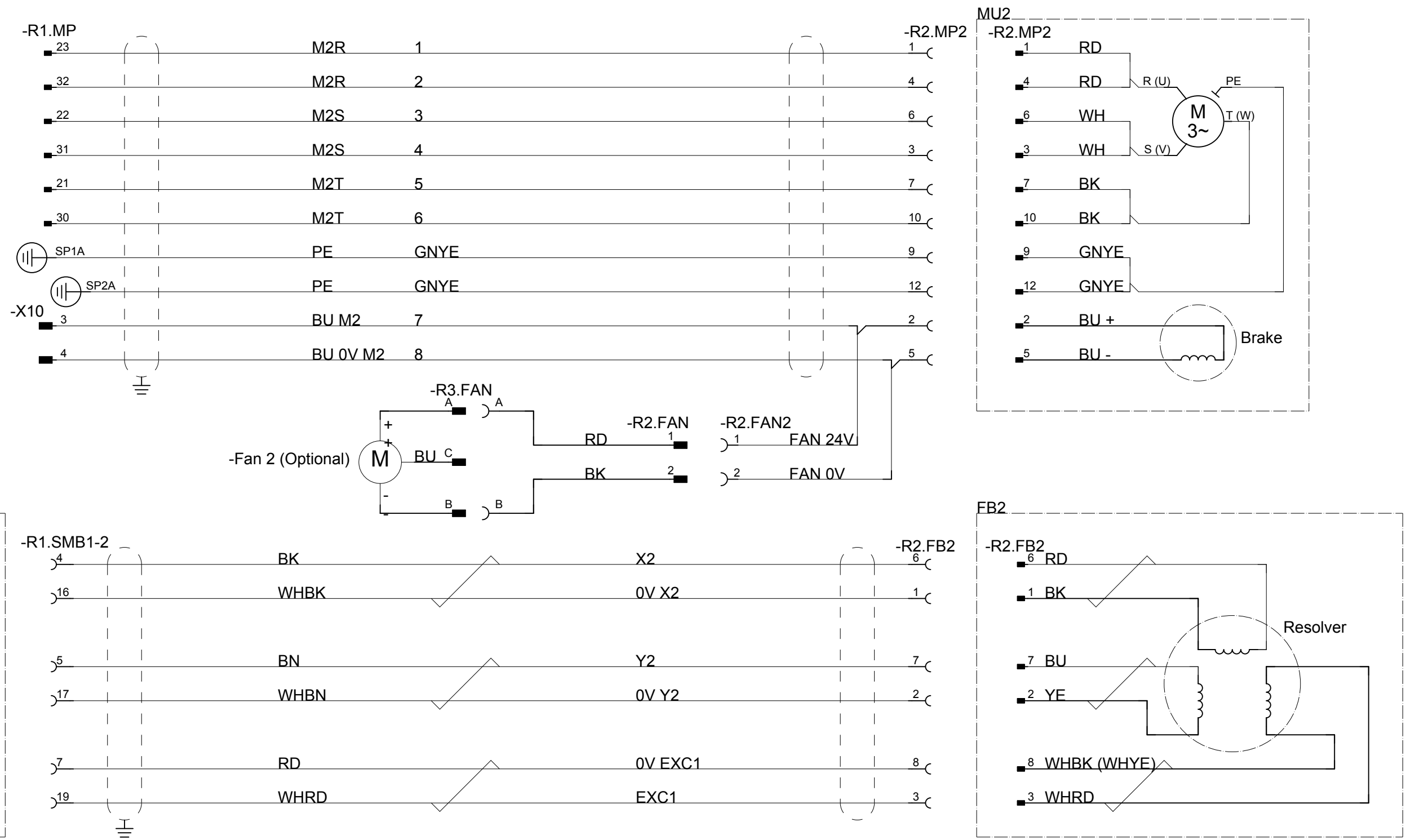

Latest revision: ECO 95019, WI 172257  
 Page 2: Page 4A & 4B; 110A & 110B added  
 Page 3: 3HAC062246-001 was 3HAC043206-001.  
 Page 5/2/5: NC & screen con. to earth added.  
 Page 4A was page 4 & page 4B is new.  
 Page 110A was page 110 & page 110B is new.

Prepared by, date: Erik Mesaros | Approved by, date: JanErik Nähls

**ABB** Lab/Office: RMRO SE/ PRIM  
 IRB 4600  
 Axis 2

Status: 2017-12-21  
 Plant: = IRB 4600  
 Location: + Axis 2  
 Sublocation: +  
**APPROVED**  
 Document no. 3HAC029038-003  
 Rev. Ind **05** Page 40  
 +Axis 3  
 Total 19

We reserve all rights in this document and in the information contained therein. Reproduction, use or disclosure to third parties without express authority is strictly forbidden. © Copyright 2003 ABB

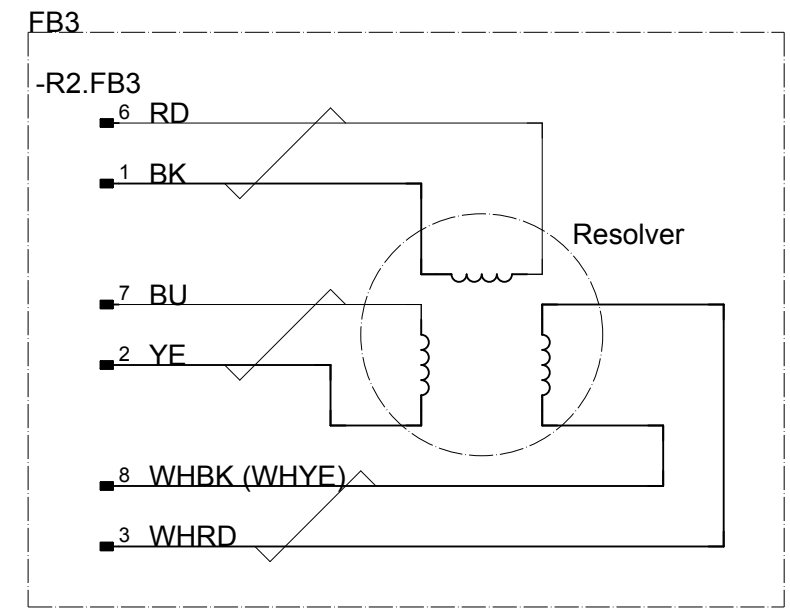
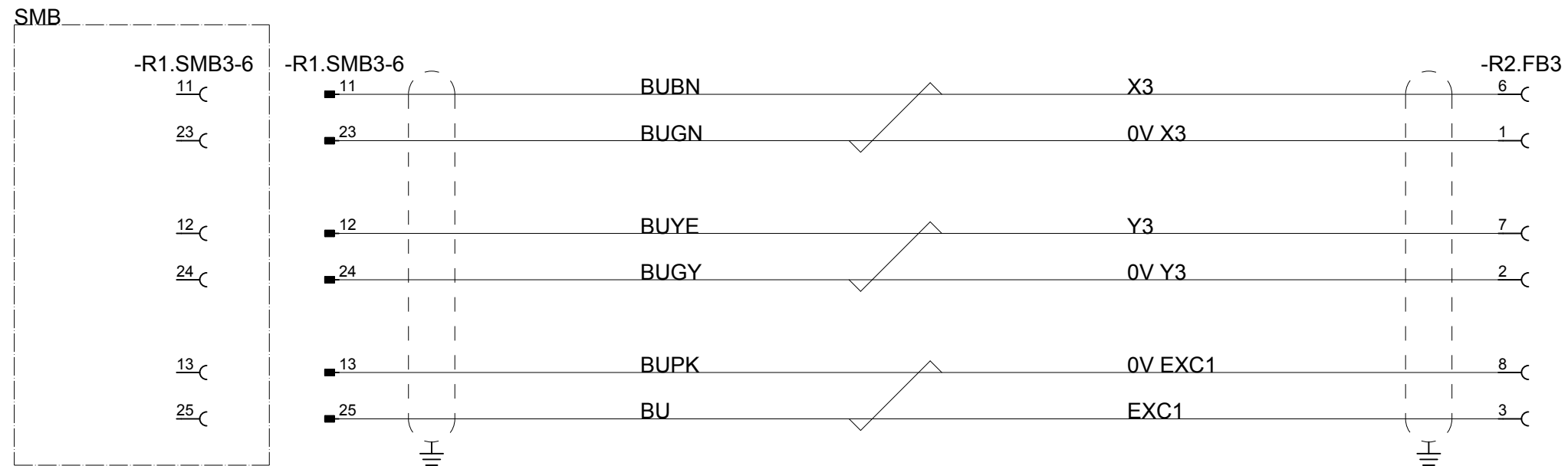
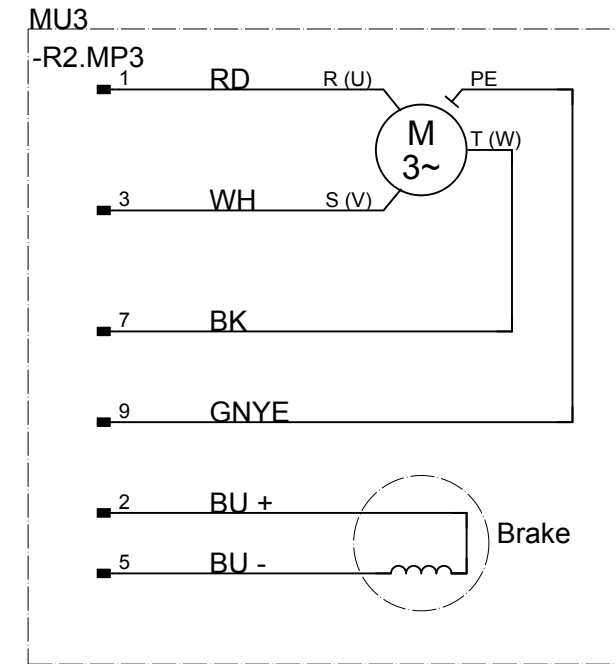
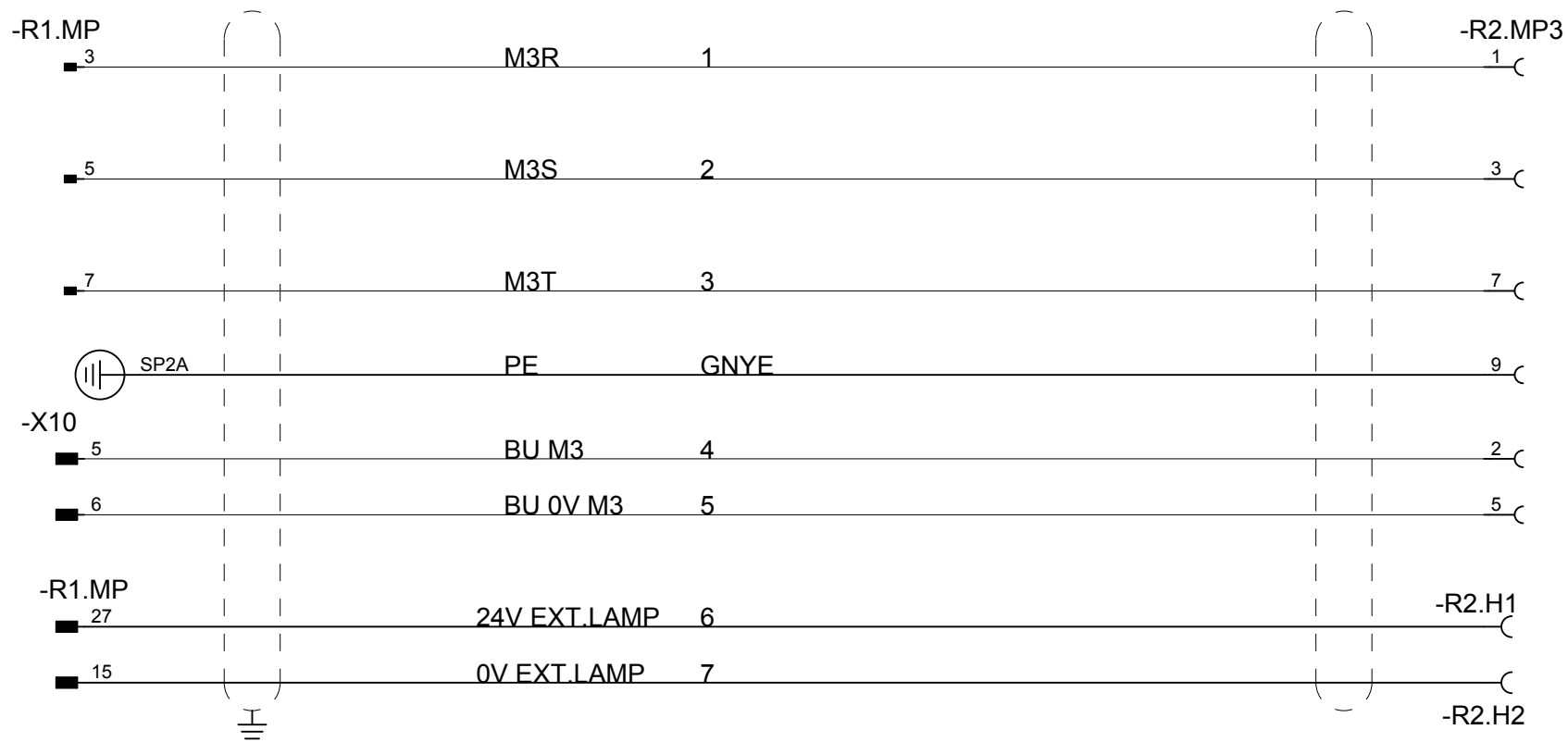

Latest revision: ECO 95019, WI 172257  
 Page 2: Page 4A & 4B; 110A & 110B added  
 Page 3: 3HAC062246-001 was 3HAC043206-001.  
 Page 5/2/5: NC & screen con. to earth added.  
 Page 4A was page 4 & page 4B is new.  
 Page 110A was page 110 & page 110B is new.

Prepared by, date: Erik Mesaros Approved by, date: JanErik Nähls



Lab/Office:  
RMRO SE/  
PRIM

IRB 4600

Axis 3

Status: 2017-12-21

APPROVED

Document no.  
3HAC029038-003

Plant: = IRB 4600  
 Location: + Axis 3  
 Sublocation: +

Rev. Ind Page50  
05 +Axis 4  
Total 19

We reserve all rights in this document and in the information contained therein. Reproduction, use or disclosure to third parties without express authority is strictly forbidden. © Copyright 2003 ABB

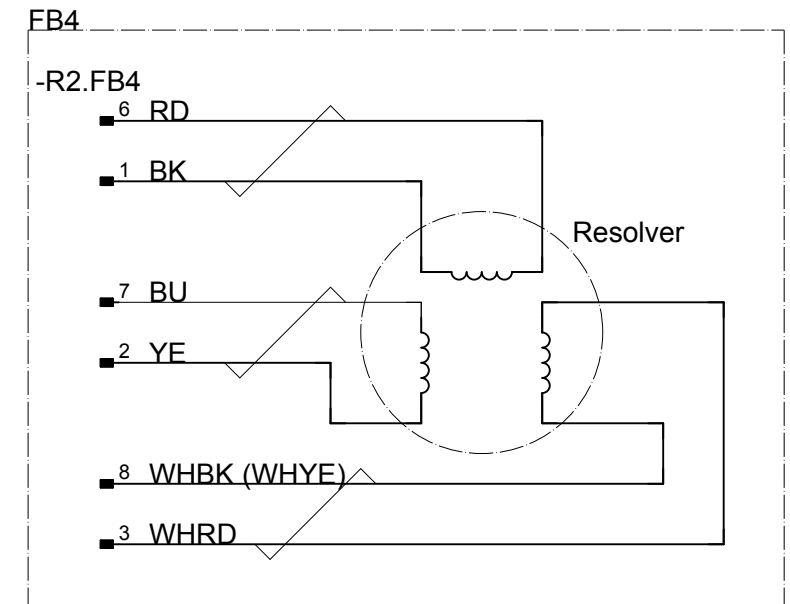
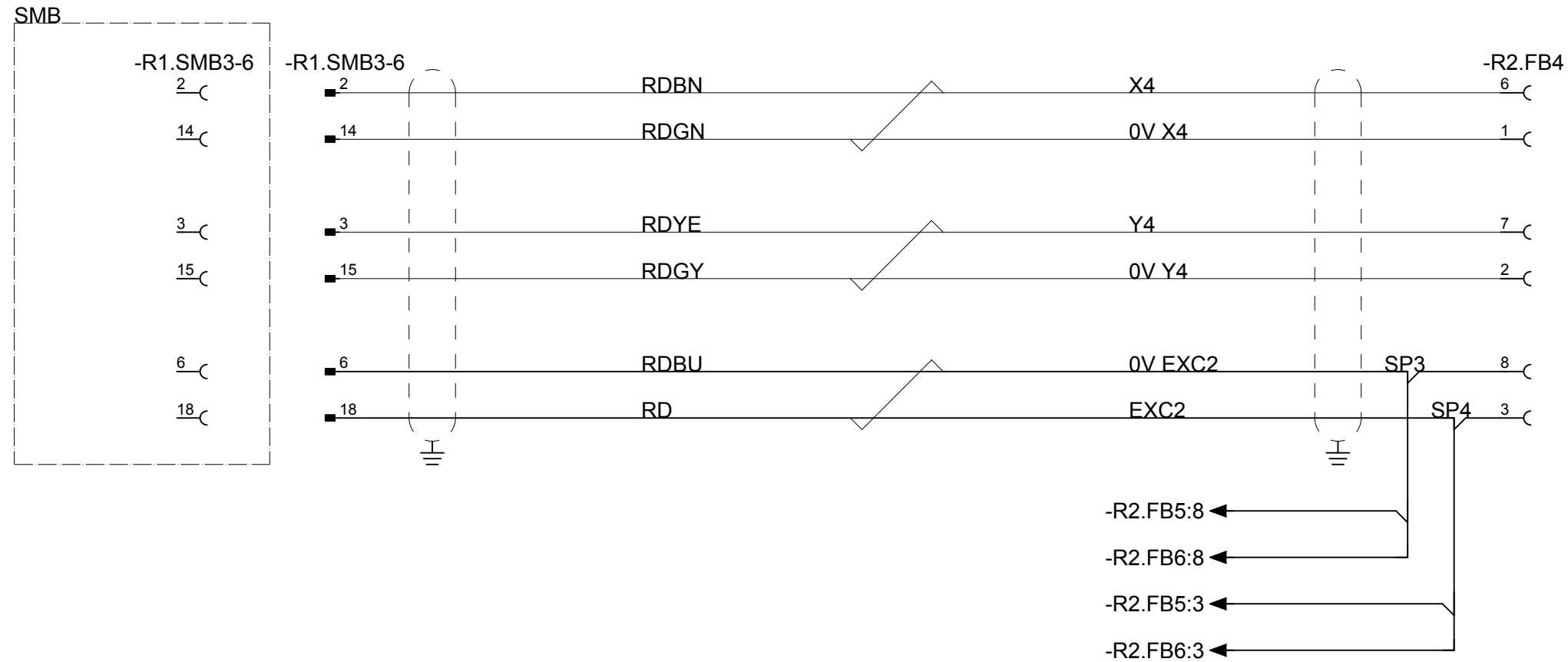
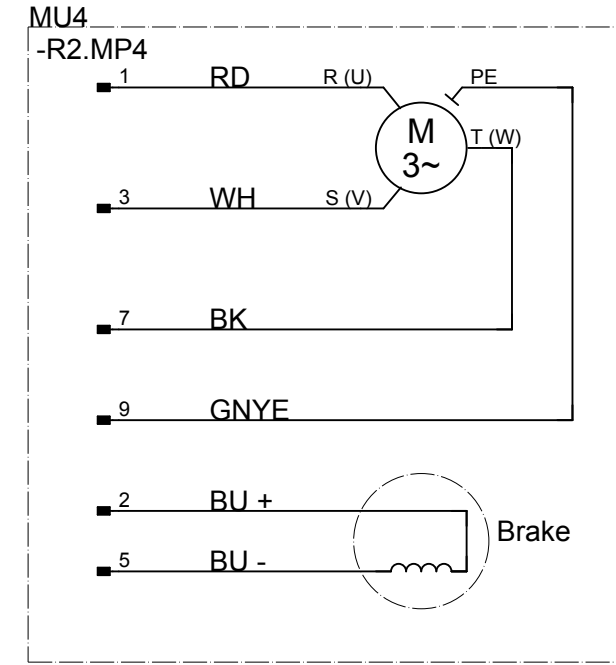
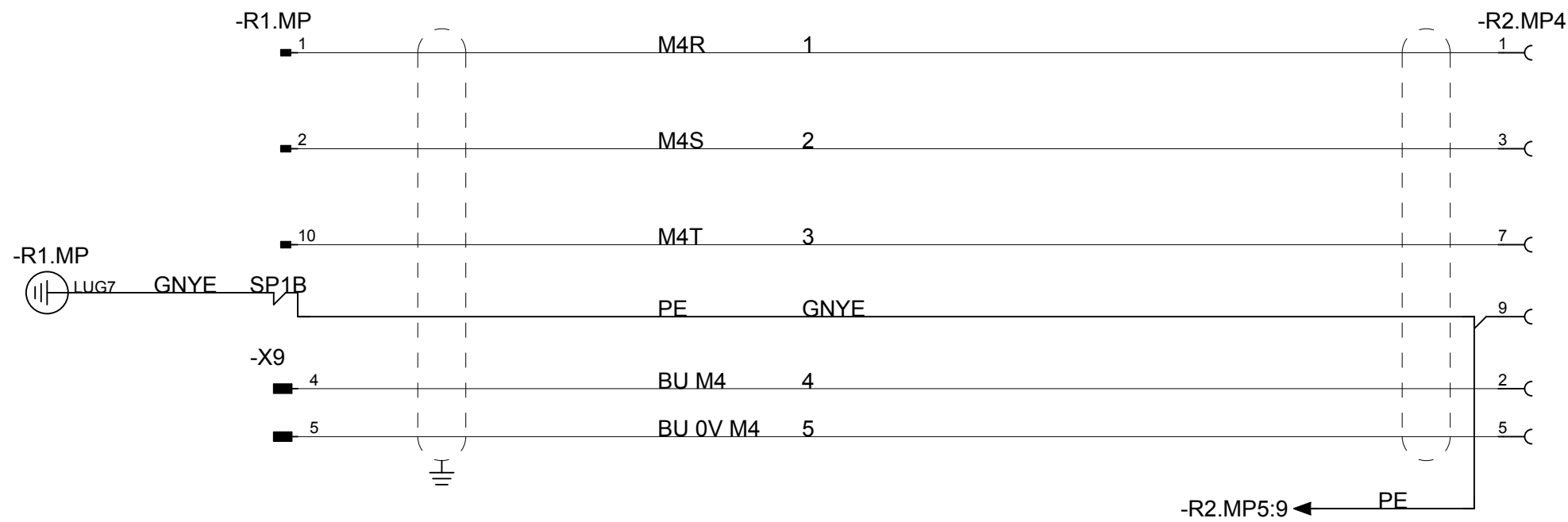

Latest revision: ECO 95019, WI 172257  
 Page 2: Page 4A & 4B; 110A & 110B added  
 Page 3: 3HAC062246-001 was 3HAC043206-001.  
 Page 5/2/5: NC & screen con. to earth added.  
 Page 4A was page 4 & page 4B is new.  
 Page 110A was page 110 & page 110B is new.

Prepared by, date: Erik Mesaros Approved by, date: JanErik Nähls



Lab/Office:  
RMRO SE/  
PRIM

IRB 4600  
Axis 4

Status: 2017-12-21

APPROVED

Document no.  
3HAC029038-003

Plant: = IRB 4600  
Location: + Axis 4  
Sublocation: +

Rev. Ind Page60  
05 +Axis 5  
Total 19

We reserve all rights in this document and in the information contained therein. Reproduction, use or disclosure to third parties without express authority is strictly forbidden. © Copyright 2003 ABB

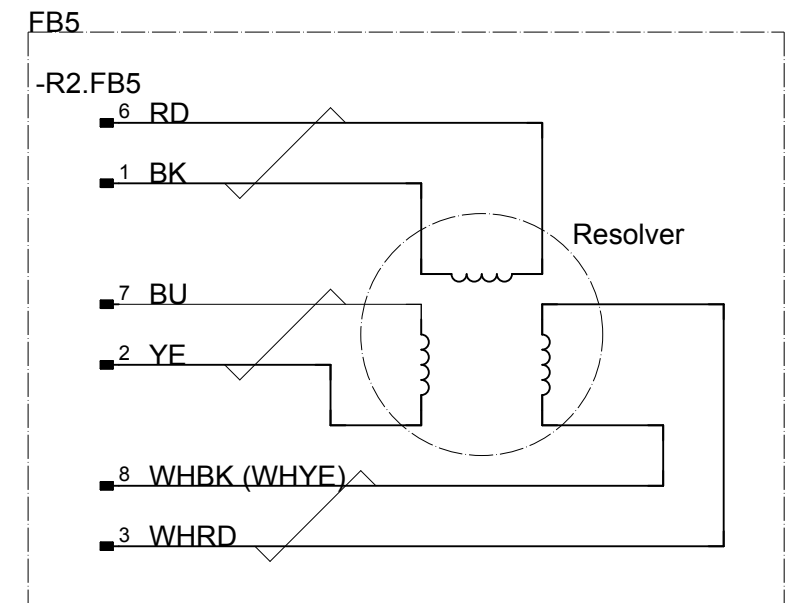
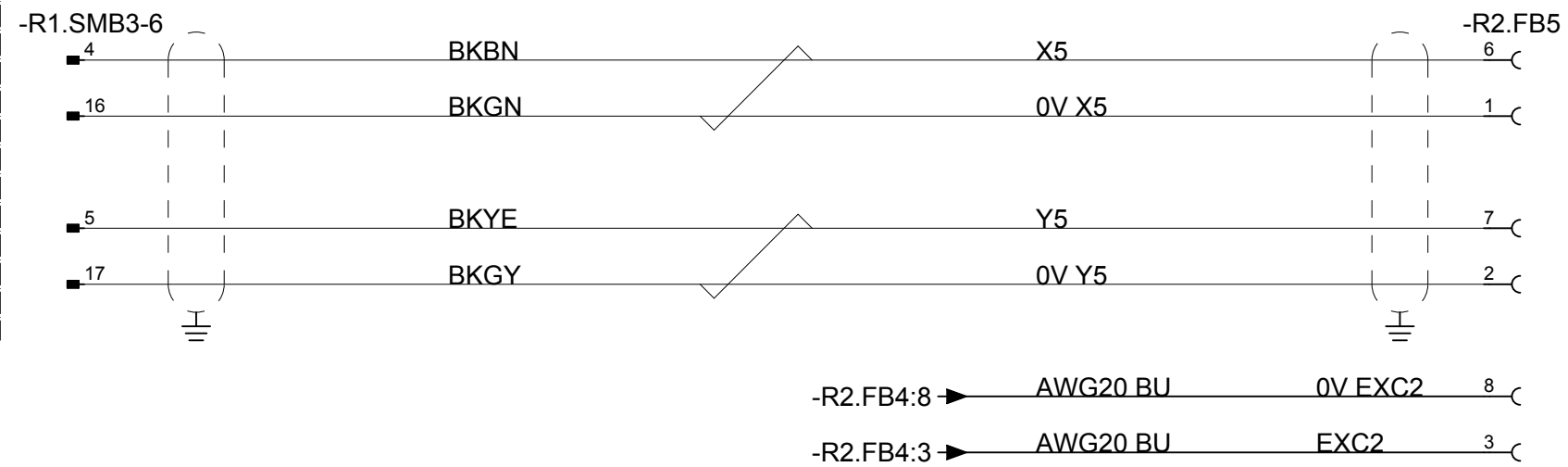
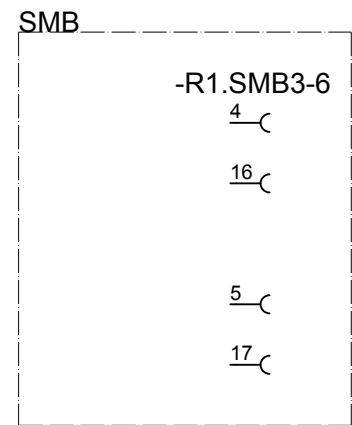
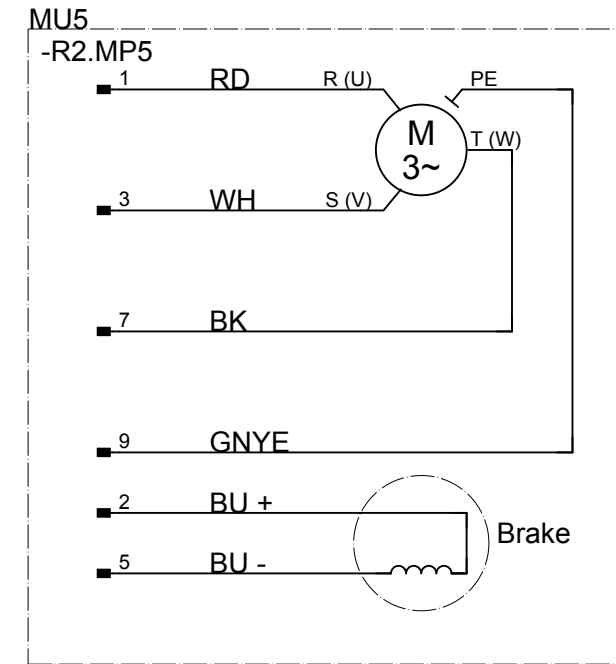
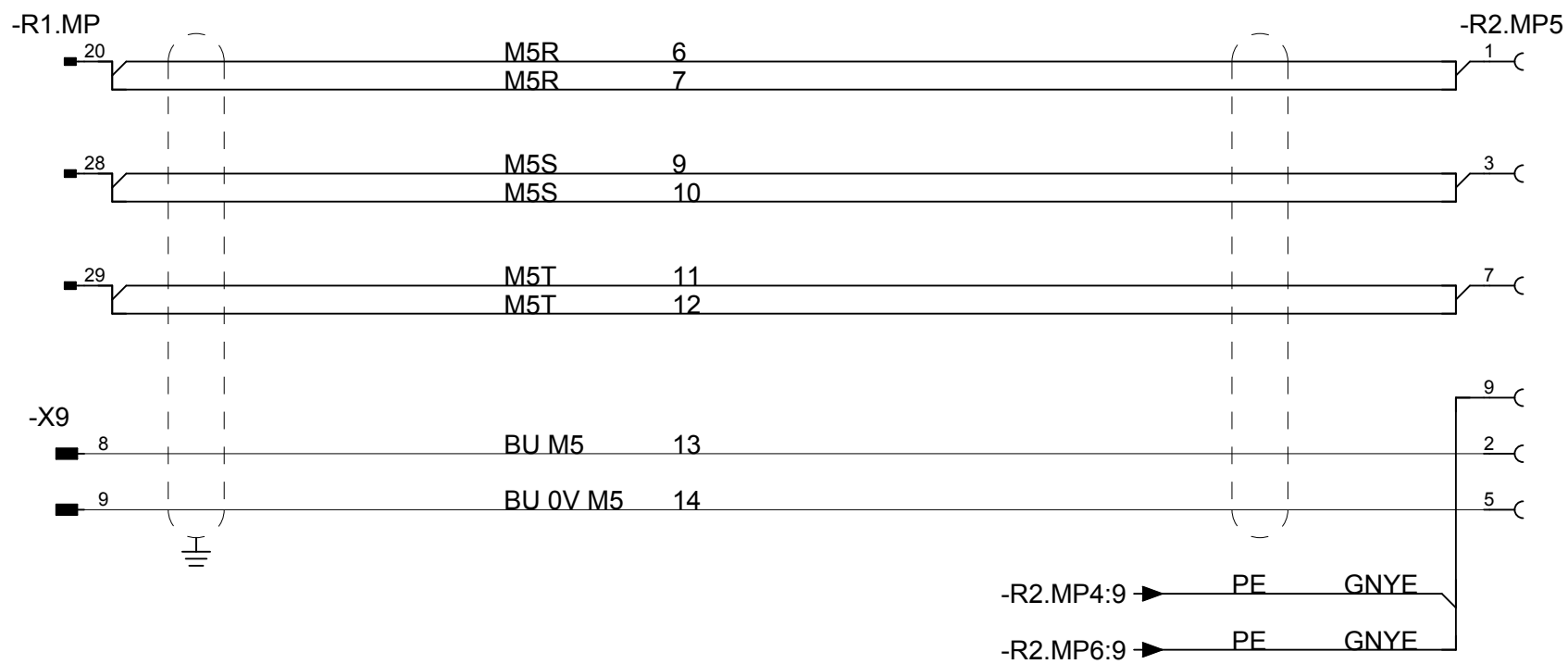

Latest revision: ECO 95019, WI 172257  
 Page 2: Page 4A & 4B; 110A & 110B added  
 Page 3: 3HAC062246-001 was 3HAC043206-001.  
 Page 5/2/5: NC & screen con. to earth added.  
 Page 4A was page 4 & page 4B is new.  
 Page 110A was page 110 & page 110B is new.

Prepared by, date: Erik Mesaros Approved by, date: JanErik Nähls



Lab/Office:  
RMRO SE/  
PRIM

IRB 4600

Axis 5

Status: 2017-12-21

APPROVED

Document no.  
3HAC029038-003

Plant: = IRB 4600  
 Location: + Axis 5  
 Sublocation: +

Rev. Ind Page70  
 05 +Axis 6  
 Total 19

We reserve all rights in this document and in the information contained therein. Reproduction, use or disclosure to third parties without express authority is strictly forbidden. © Copyright 2003 ABB

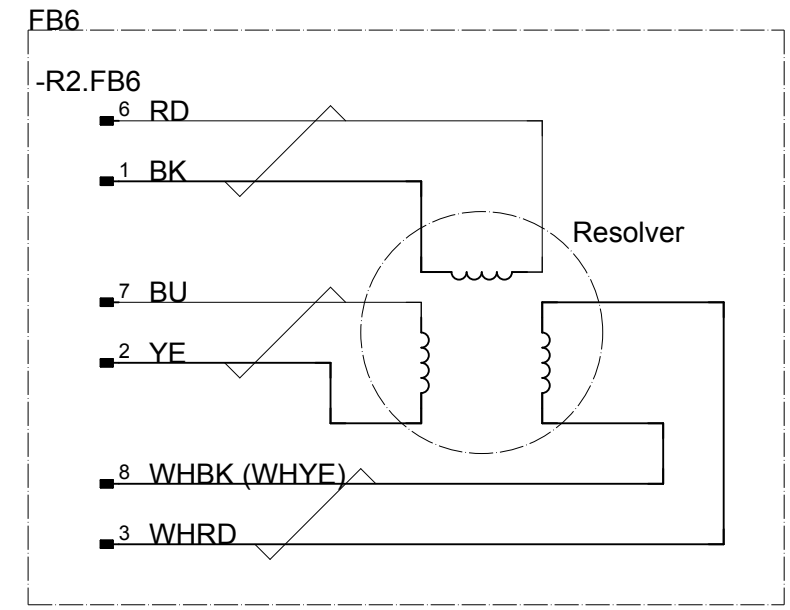
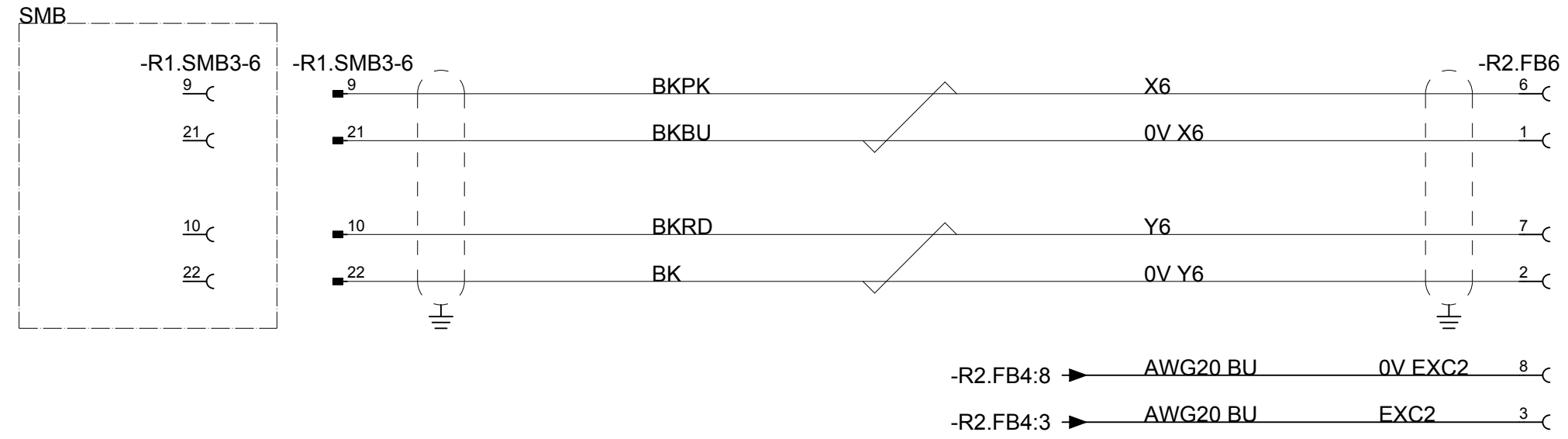
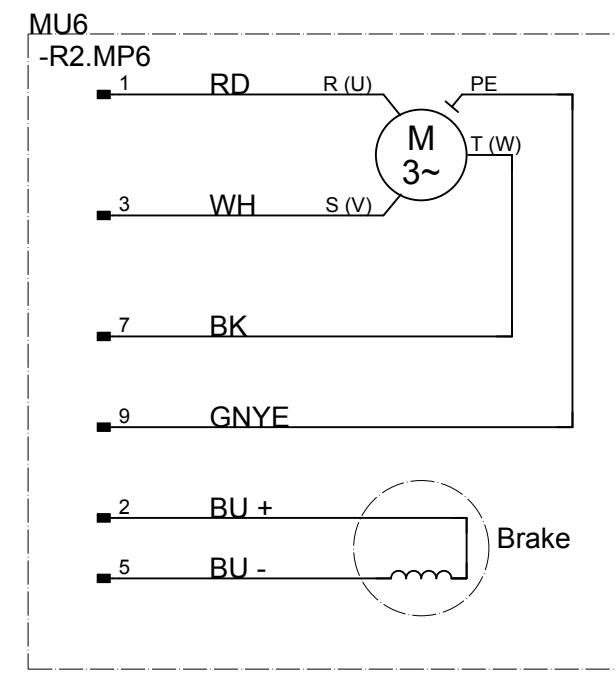
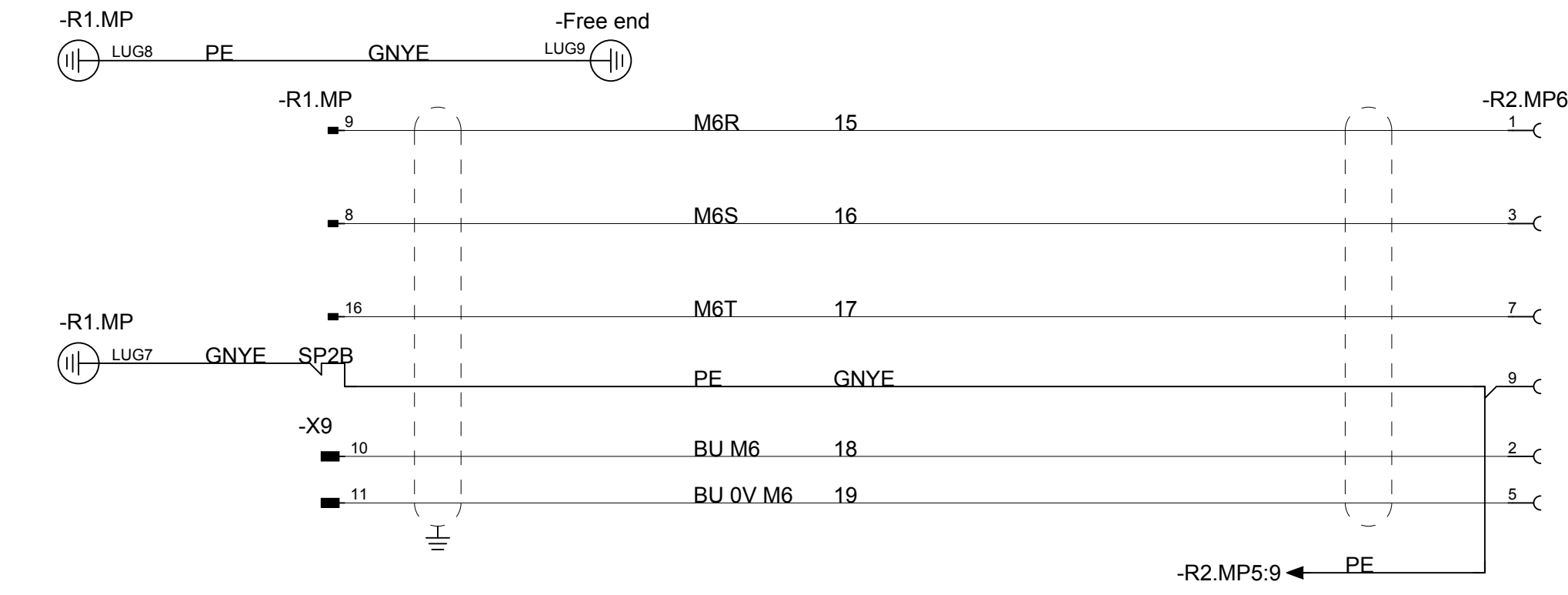

Latest revision: ECO 95019, WI 172257  
 Page 2: Page 4A & 4B; 110A & 110B added  
 Page 3: 3HAC062246-001 was 3HAC043206-001.  
 Page 5/2/5: NC & screen con. to earth added.  
 Page 4A was page 4 & page 4B is new.  
 Page 110A was page 110 & page 110B is new.

Prepared by, date: Erik Mesaros | Approved by, date: JanErik Nähls



Lab/Office: IRB 4600  
 RMRO SE/  
 PRIM  
 Axis 6

Status: 2017-12-21  
 Plant: = IRB 4600  
 Location: + Axis 6  
 Sublocation: +  
**APPROVED**  
 Document no. 3HAC029038-003  
 Rev. Ind 05  
 Page 80  
 +CP/CS  
 Total 19

We reserve all rights in this document and in the information contained therein. Reproduction, use or disclosure to third parties without express authority is strictly forbidden. © Copyright 2003 ABB

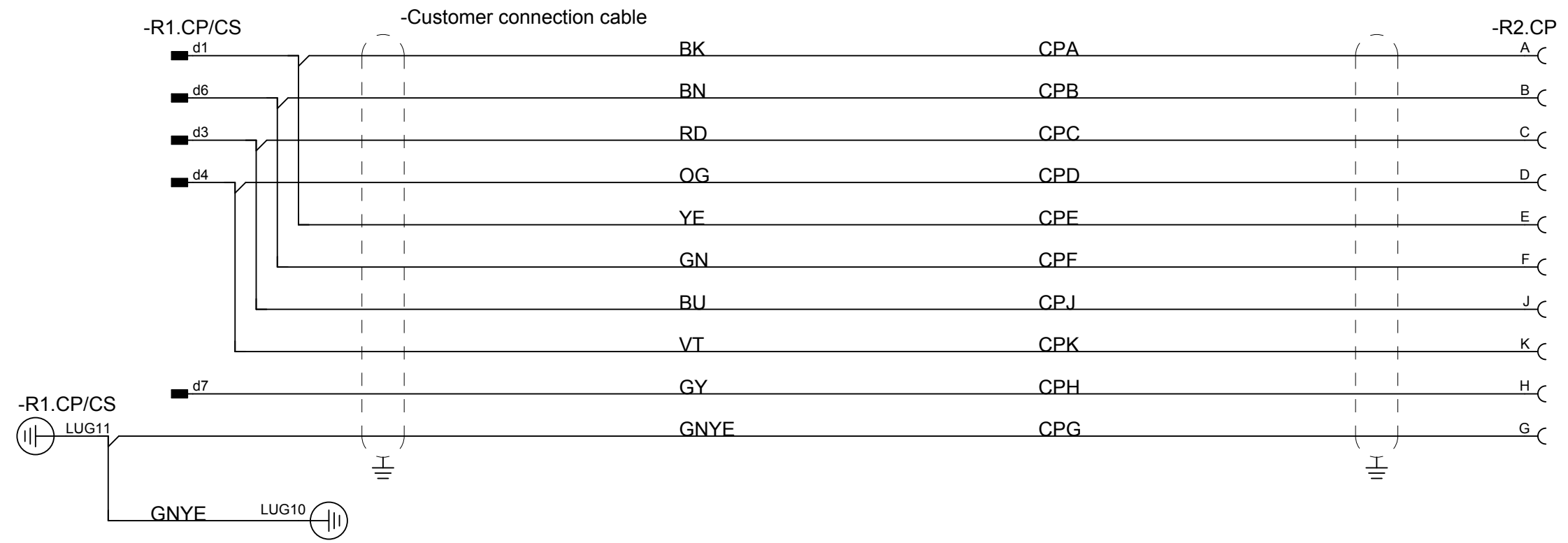

Latest revision: ECO 95019, WI 172257  
 Page 2: Page 4A & 4B; 110A & 110B added  
 Page 3: 3HAC062246-001 was 3HAC043206-001.  
 Page 5/2/5: NC & screen con. to earth added.  
 Page 4A was page 4 & page 4B is new.  
 Page 110A was page 110 & page 110B is new.

Prepared by, date: Erik Mesaros | Approved by, date: JanErik Nähls



Lab/Office:  
 RMRO SE/  
 PRIM

IRB 4600  
 Customer connection

Status: 2017-12-21  
**APPROVED**

Plant: = IRB 4600  
 Location: + CP/CS  
 Sublocation: +

Document no. 3HAC029038-003 | Rev. Ind 05 | Page 90 | 100 | Total 19

We reserve all rights in this document and in the information contained therein. Reproduction, use or disclosure to third parties without express authority is strictly forbidden. © Copyright 2003 ABB

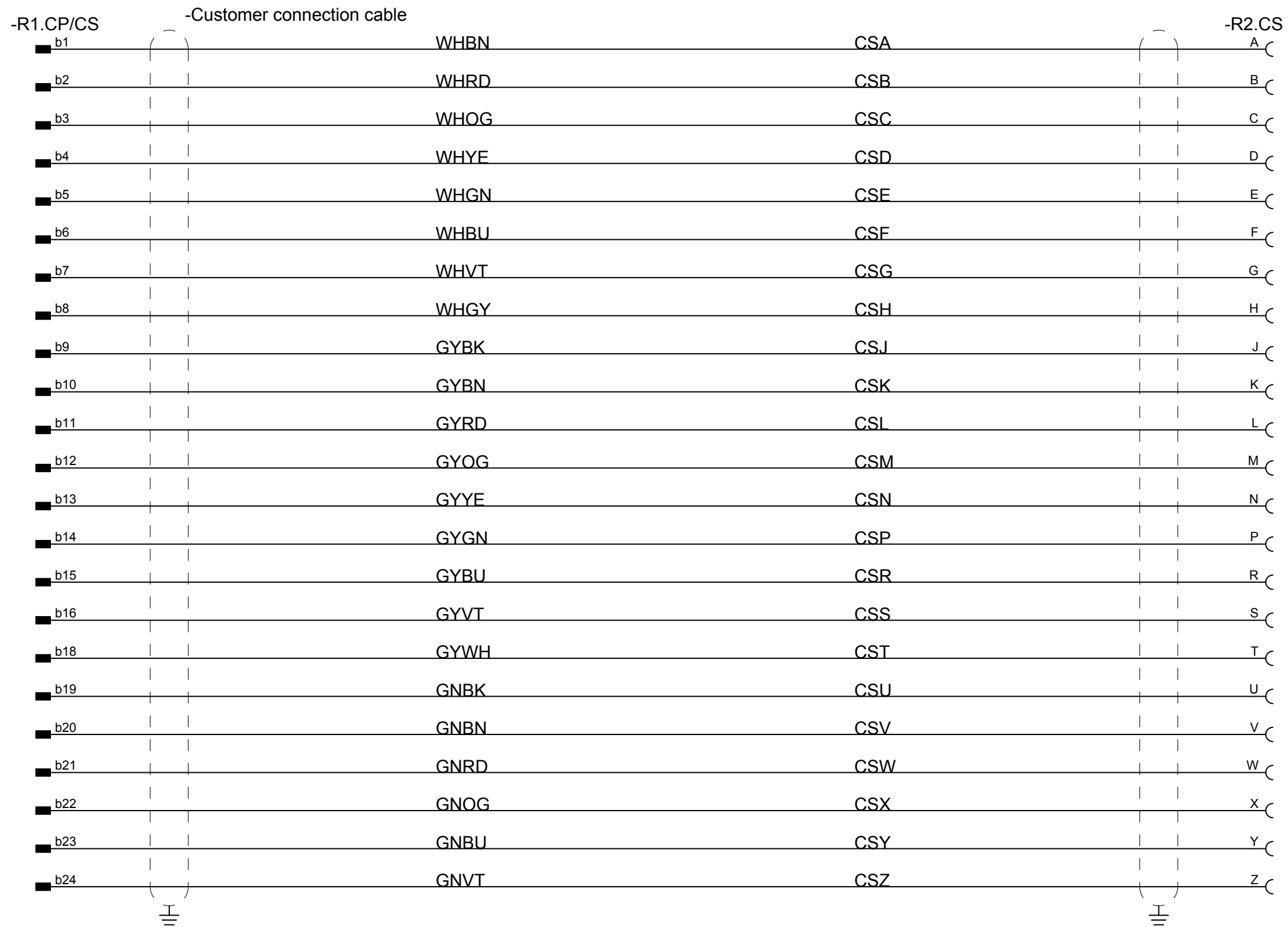



We reserve all rights in this document and in the information contained therein. Reproduction, use or disclosure to third parties without express authority is strictly forbidden. © Copyright 2003 ABB

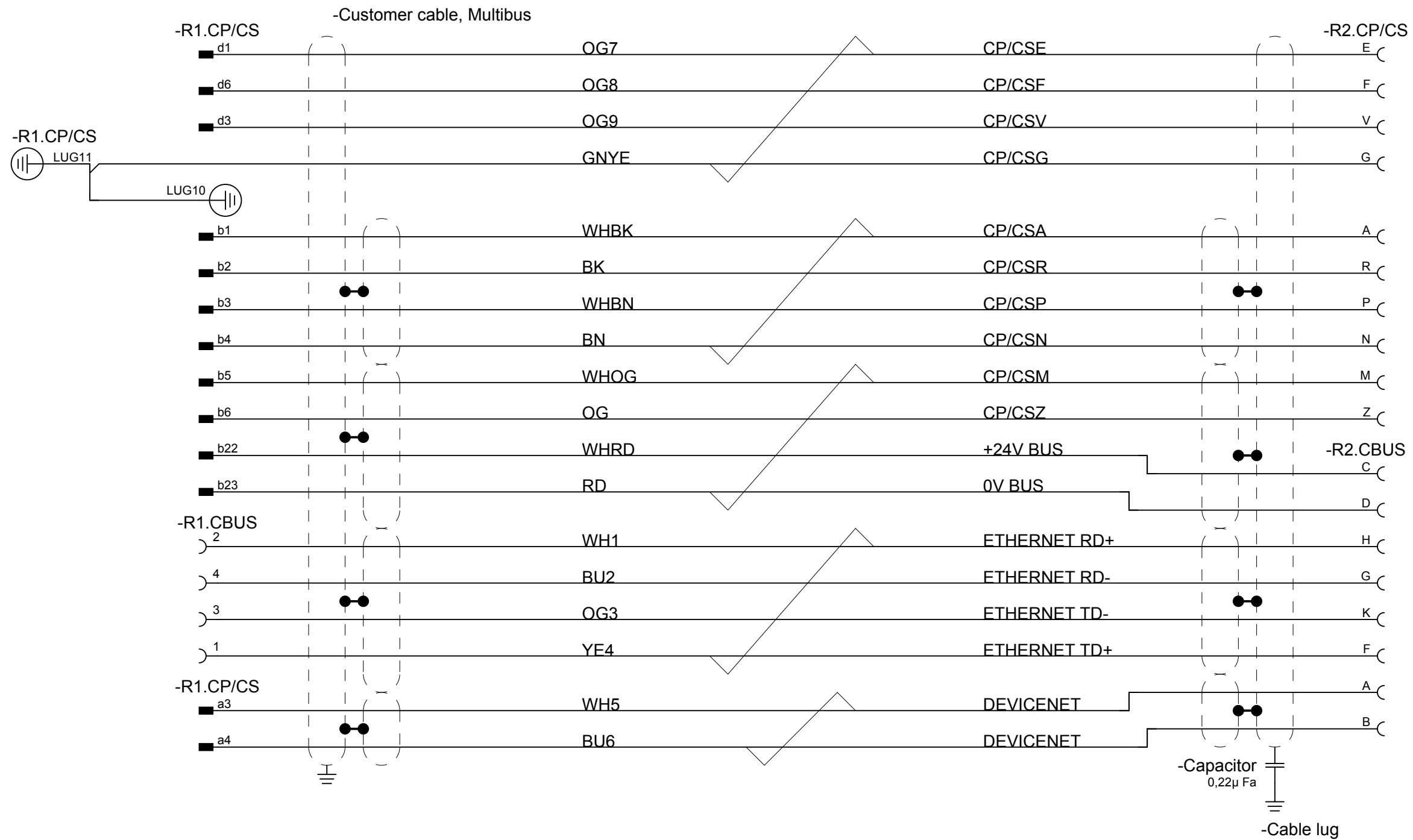

Latest revision: ECO 95019, WI 172257  
 Page 2: Page 4A & 4B; 110A & 110B added  
 Page 3: 3HAC062246-001 was 3HAC043206-001.  
 Page 5/2/5: NC & screen con. to earth added.  
 Page 4A was page 4 & page 4B is new.  
 Page 110A was page 110 & page 110B is new.

Prepared by, date: Erik Mesaros Approved by, date: JanErik Nähls



Lab/Office:  
RMRO SE/  
PRIM

IRB 4600  
Multibus, old

Status: 2017-12-21

**APPROVED**

Document no.  
3HAC029038-003

Plant: = IRB 4600  
Location: + Multibus  
Sublocation: +

Rev. Ind Page110A  
**05** +Profib  
Total 19

We reserve all rights in this document and in the information contained therein. Reproduction, use or disclosure to third parties without express authority is strictly forbidden. © Copyright 2003 ABB

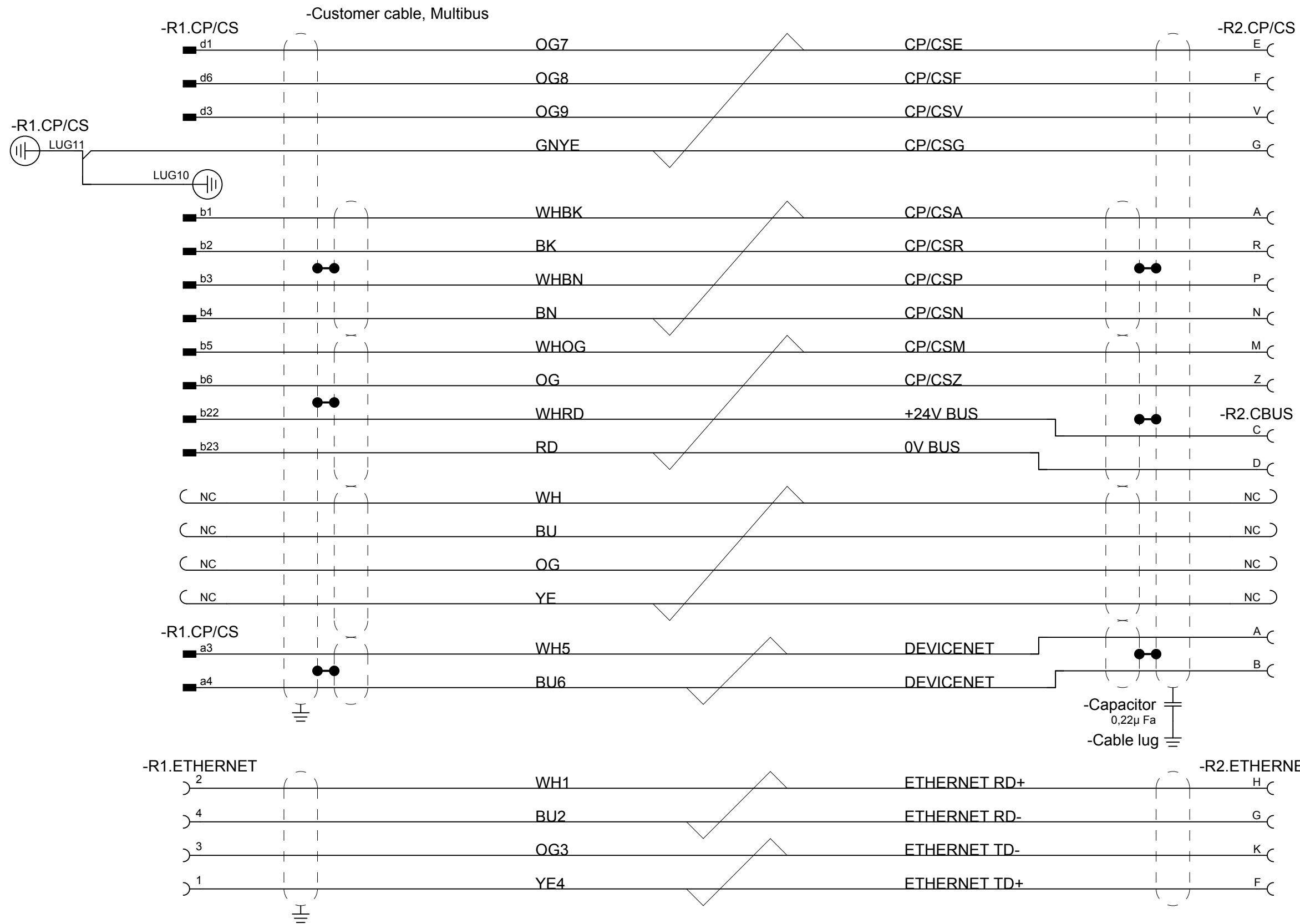

Latest revision: ECO 95019, WI 172257  
 Page 2: Page 4A & 4B; 110A & 110B added  
 Page 3: 3HAC062246-001 was 3HAC043206-001.  
 Page 5/2/5: NC & screen con. to earth added.  
 Page 4A was page 4 & page 4B is new.  
 Page 110A was page 110 & page 110B is new.

Prepared by, date: Erik Mesaros Approved by, date: JanErik Nähls



Lab/Office:  
RMRO SE/  
PRIM

IRB 4600

Multibus, new

Status: 2017-12-21

**APPROVED**

Document no.

3HAC029570-007

Plant: = IRB 4600  
 Location: + Multibus  
 Sublocation: +

Rev. Ind

**05**

Page 110B

+Manip  
Total 19

We reserve all rights in this document and in the information contained therein. Reproduction, use or disclosure to third parties without express authority is strictly forbidden. © Copyright 2003 ABB

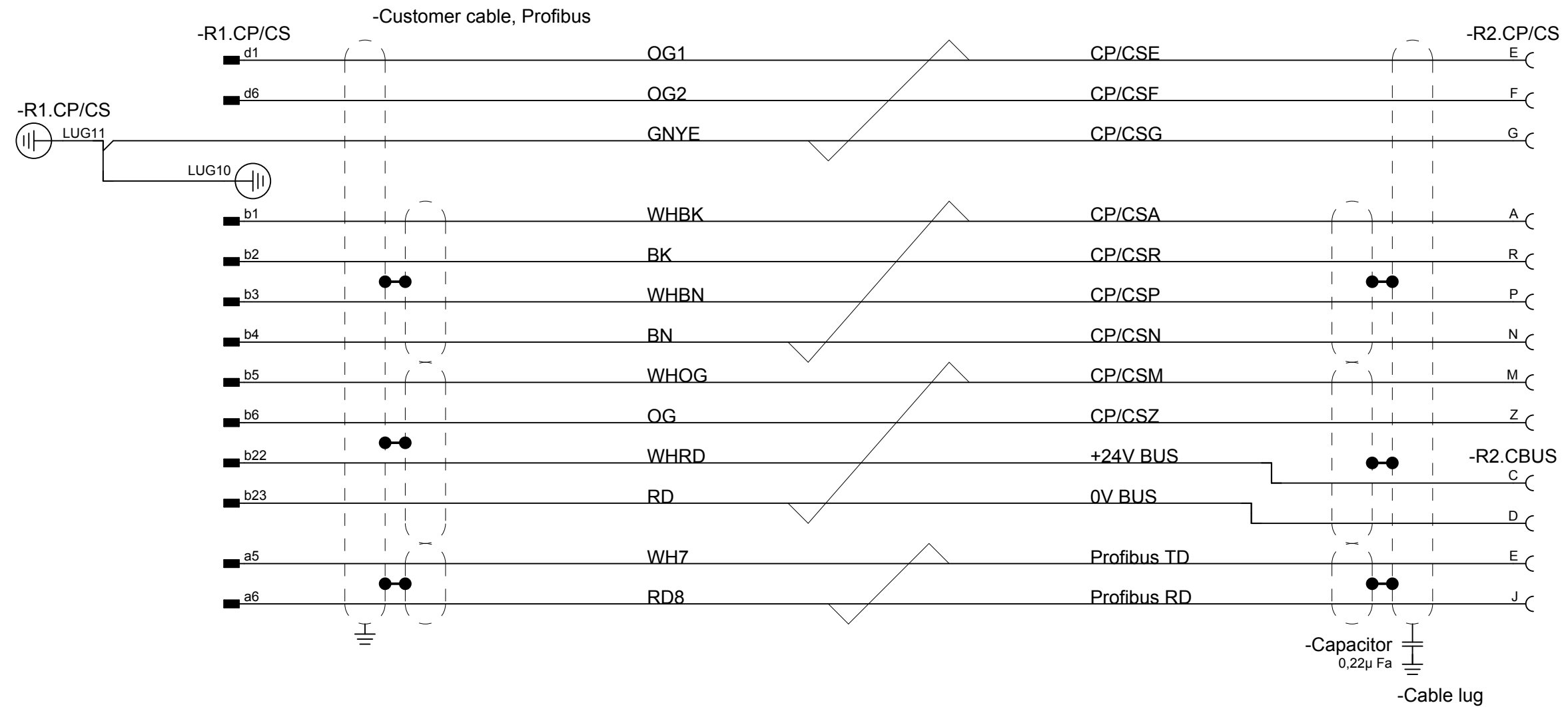

Latest revision: ECO 95019, WI 172257  
 Page 2: Page 4A & 4B; 110A & 110B added  
 Page 3: 3HAC062246-001 was 3HAC043206-001.  
 Page 5/2/5: NC & screen con. to earth added.  
 Page 4A was page 4 & page 4B is new.  
 Page 110A was page 110 & page 110B is new.



Lab/Office:  
RMRO SE/  
PRIM

IRB 4600

Profibus

Status: 2017-12-21

**APPROVED**

Document no.  
**3HAC029038-003**

Plant: = IRB 4600  
 Location: + Profibus  
 Sublocation: +

Rev. Ind **05** Page 120  
 +Multib  
 Total 19

Prepared by, date: Erik Mesaros Approved by, date: JanErik Nähls